

## FITTING INSTRUCTION

Clamp mark in acc. with		Cables joining
ISO	PN	
1	L	Left directional lights
2	+	Rear fog lights
3	31	Ground
4	R	Right directional lights
5	58R	Right side parking lights
6	54	Stoptlights
7	58L	Left side parking lights

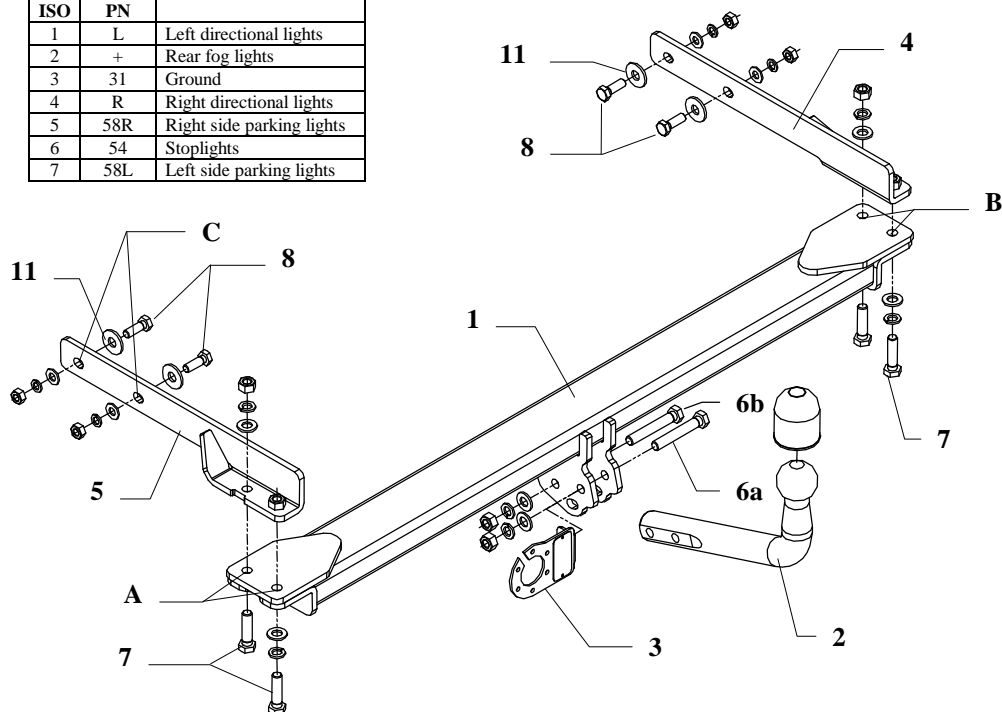

This towbar is designed to assembly in following car:

**MERCEDES 124, 4 doors, Cabrio, Coupe** produced since 1985 till 05.1995, catalogue no. **D02** and is prepared to tow trailers max total weight **1900 kg** and max vertical load **75 kg**.

### *From manufacturer*

Thank you for buying our product. Their reliability has been confirmed in many tests. Reliability of towbar depends also on correct assembly and right operation. For this reasons we kindly ask to read carefully this instruction and apply to hints.

*The towbar should be install in points described by a car producer.*

## The instruction of the assembly

1. Disassemble the bumper, detach the muffler from bands and remove thermal shield over muffler.
2. Find factory marked points on left and right side of chassis and next drill holes (pos. A and B) with bit  $\varnothing 15\text{mm}$ .
3. To tunnels on the left and right side of spare wheel hollow put side brackets (pos. 4 and 5) and using bolts M12x45mm (pos. 8) fix it through made holes (pos. A and B) with main element pos. 1 (element 1 put underneath the car).
4. On the right side in spare wheel hollow are holes. Through this holes fix towbar using bolts M10x30mm pos. 8 from accessories.
5. On the left side, in factory marked points drill holes (pos. C) through chassis using bit  $\varnothing 11\text{mm}$  and next fix using bolts M10x30mm (pos. 8) from accessories.
6. Mount the thermal shield, the muffler and the rear bumper.
7. Fix tow ball (pos. 2) and socket plate (pos. 3) using bolts M12x75mm (pos. 6a) and M12x70mm (pos. 6b) from accessories.
8. Tighten all bolts according to the torque shown in the table.
9. Connect electric wires of 7-pole socket according to the instruction of the car. (Recommend to make at authorized service station)
10. Complete paint layer damaged during installation.

Torque settings for nuts and bolts (8,8):

<b>M8</b>	25 Nm	<b>M10</b>	55 Nm
<b>M12</b>	85 Nm	<b>M14</b>	135 Nm











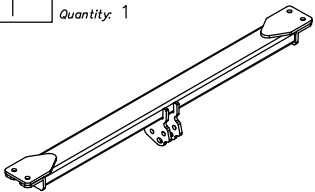
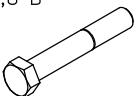

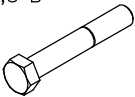
### NOTE

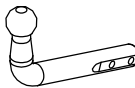
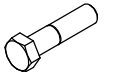
After install the towbar you should get adequate note in registration book (at authorised service station).The car should be equipped with:

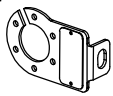
- Indicators
- Tow mirrors

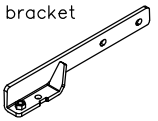
After 1000km check all bolts and nuts. The ball of towbar must be always kept clear and conserve with a grease.

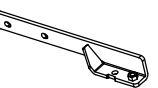
## Towbar accessories:

Pos. 1 Name: Main bar Quantity: 1 	Pos. 6a Name: Bolt 8,8 B Quantity: 1 Dim.: M12x75mm 	Pos. 11 Name: Washer Quantity: 4 Dim.: Ø32xØ12x3mm 
	Pos. 6b Name: Bolt 8,8 B Quantity: 1 Dim.: M12x70mm 	Pos. 12 Name: Plain washer Quantity: 6 Dim.: Ø 13 mm 
Pos. 2 Name: Tow ball Quantity: 1 	Pos. 7 Name: Bolt 8,8 B Quantity: 4 Dim.: M12x45mm 	Pos. 13 Name: Plain washer Quantity: 4 Dim.: Ø 10,5 mm 
Pos. 3 Name: Socket plate Quantity: 1 	Pos. 8 Name: Bolt 8,8 B Quantity: 4 Dim.: M10x30mm 	Pos. 14 Name: Spring washer Quantity: 6 Dim.: Ø 12,2 mm 
Pos. 4 Name: Right bracket Quantity: 1 	Pos. 9 Name: Nut 8 B Quantity: 4 Dim.: M12 	Pos. 15 Name: Spring washer Quantity: 4 Dim.: Ø 10,2 mm 
Pos. 5 Name: Left bracket Quantity: 1 	Pos. 10 Name: Nut 8 B Quantity: 4 Dim.: M10 	Pos. 16 Name: Ball cover Quantity: 1 



**PPUH AUTO-HAK S.J.**

Produkcja Haków Holowniczych  
 Henryk & Zbigniew Nejman  
 76-200 SŁUPSK ul. Słoneczna 16K  
 tel/fax (059) 8-414-414; 8-414-413  
 E-mail: [office@autohak.com.pl](mailto:office@autohak.com.pl)  
[www.autohak.com.pl](http://www.autohak.com.pl)

## Towing hitch (without electrical set)

Class: **A50-X** Cat. no. **D02**

Designed for:

Manufacturer: **MERCEDES**

Model: **124**

Type: **4 doors, Cabrio, Coupe**

produced since 1985 till 05.1995

Technical data:

**D-value: 9,8 kN**

maximum trailer weight: **1900 kg**

maximum vertical cup load: **75 kg**

Approval number acc. to regulations EKG/ONZ 55.01: **E20-55R-01 1339**

## Foreword

This towbar is designed according to rules of safety traffic regulations. The towing hitch is a safety component and can be install only by qualified personnel. Any alteration or conversion of the towing hitch is prohibited and would lead to cancellation of design certification. Remove insulating compound and underseal from vehicle (if present) in the area of the matting surfaces of the towing hitch. The vehicle manufacturer's specifications regarding trailer load and max. vertical cup load are decisive for driving, and values for the towing hitch cannot be exceeded.

*D-value formula:*

$$\frac{\text{Max trailer weight [kg]} \times \text{Max vehicle weight [kg]}}{\text{Max trailer weight [kg]} + \text{Max vehicle weight [kg]}} \times \frac{9,81}{1000} = D \text{ [kN]}$$